

# [ mod. 76 ]

Thermoprinting and finishing of ribbons

I >>

La calandra mod. 76 è stata progettata per la termo stampa ed il termo fissaggio di nastri, etichette e tessuti stretti. Grazie alle dimensioni molto compatte il mod. 76 offre un'ottima soluzione per tutti i clienti che intendono stampare nastri e/o tessuti stretti con la tecnologia della stampa digitale, o comunque per produzioni limitate. Il mod. 76 è in grado di lavorare sia con carte digitali sia con carte tradizionali.

## [ CARATTERISTICHE ]

- > Versatilità e facilità d'uso
- > Minimo ingombro e consumo elettrico
- > Voltaggio 230 V monofase
- > Entrata e uscita carta protezione
- > Entrata e uscita carta stampa
- > Uscita nastri tramite rullo gommato e motorizzato
- > Rullo sbattitore per raddrizzare nastri provenienti da scatole (Optional)
- > Feltro in NOMEX

GB >>

The calender mod. 76 was studied for thermoprinting and thermosetting ribbons, labels and narrow textiles. Thanks to its compact dimensions, mod. 76 offers an excellent solution for all the customers who want to print ribbons and/or narrow textiles with digital printing technology, or however for limited quantities. Mod. 76 can work both with digital paper as well as with traditional paper.

## [ CHARACTERISTICS ]

- > Versatility and ease to use
- > Minimum footprint and electrical consumption
- > Voltage 230 V monophas
- > Protection paper entry and exit
- > Printing paper entry and exit
- > Ribbons exit thanks rubber coated and motorized roll
- > Flattener for straightening ribbons coming from boxes (Option)
- > NOMEX felt



**MONTI ANTONIO®**

STANDARD & CUSTOM HEATING SOLUTIONS



## [ Technical data ]

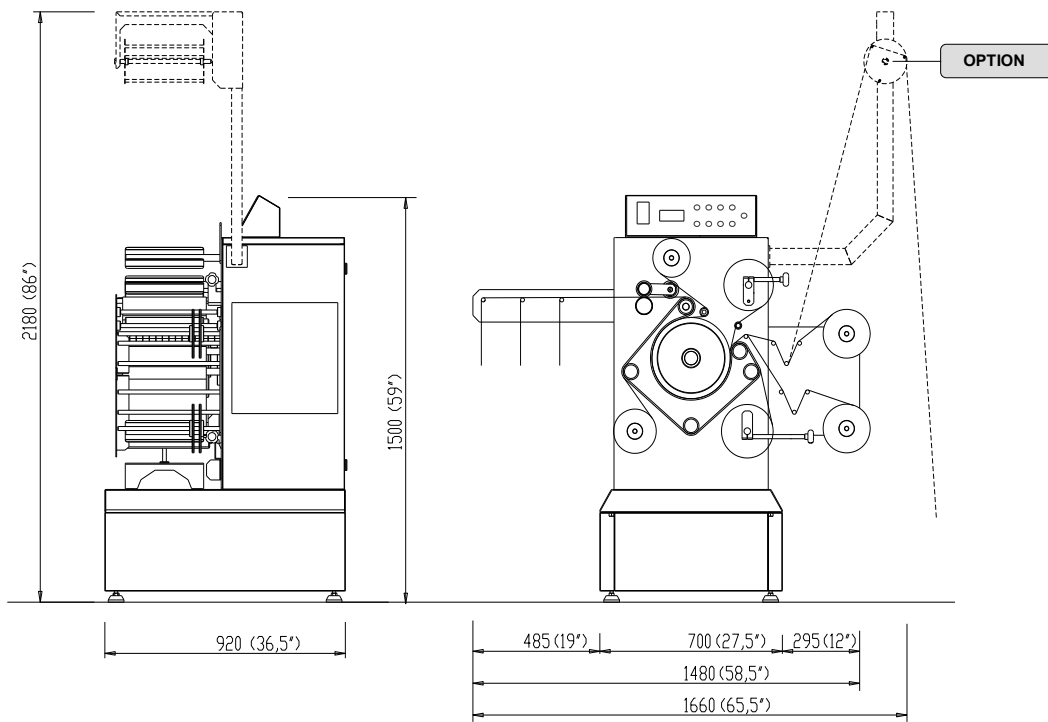

Diametro cilindro / Cylinder diameter	mm	300 (12'')
Tavola cilindro / Cylinder width	mm.	300 (12'')
Tavola utile / Working width	mm.	250 (10'')
Potenza elettrica installata / Installed electric power	Kw	3,5
Consumo medio / Average consumption	Kw/h	2,5
Velocità meccanica / Mechanical speed	m/min.	0,3÷3
Peso netto / Net weight	Kg	260

I DATI E LE CARATTERISTICHE TECNICHE SONO PURAMENTE INDICATIVI E SOGGETTI A VARIAZIONI SENZA OBBLIGO DI PREAVVISO.  
THE DATA AND TECHNICAL FEATURES ARE PURELY INDICATIVE AND SUBJECT TO CHANGES WITHOUT NOTICE

台灣代理商:  **WEI CHIH** 威至有限公司

24158 新北市三重區重新路五段639-3號7樓 (由661巷進入 金陵科技大樓)  
7F, No.639-3, Sec. 5, Chongsin Rd., Sanchong Dist., New Taipei City 24158, Taiwan (R.O.C)  
TEL : 886-2-77306333 FAX : 886-2-29955928  
www.weitechtw.com

member of  **ACIMIT**  
ITALIAN TEXTILE  
MACHINERY



Monti Antonio S.p.A.  
Via dell'Electronica n°5  
36016 Thiene (VI) - Italy

Tel. +39 0445 364619  
Fax. +39 0445 364033  
sales@montiantonio.com  
www.montiantonio.com

STANDARD & CUSTOM HEATING SOLUTIONS



LAMINATING



PRINTING



FINISHING



PRESSING



STEAM BOILERS